

HYDRAULIC CYLINDER WITH FRONT FLANGE, DA 250

Performance DA0501

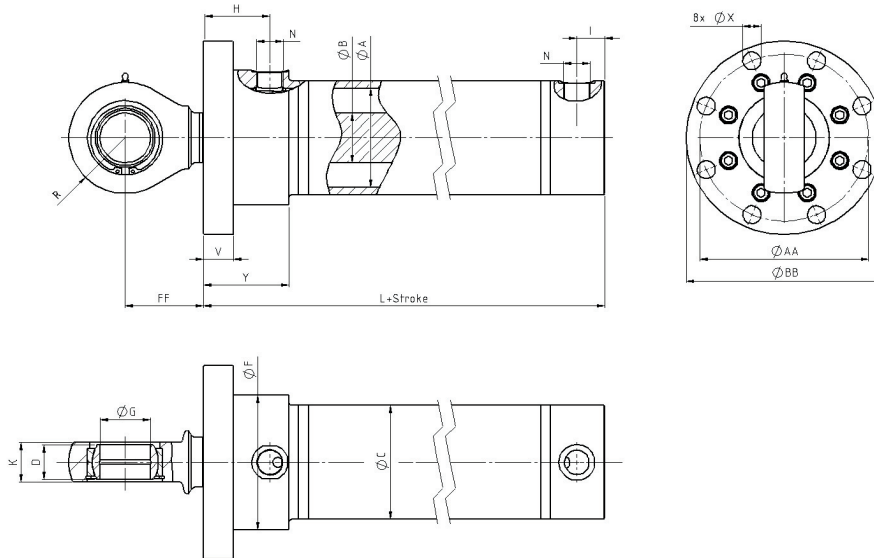

All measures in mm, if nothing else is stated.
Maximum working pressure 25.0 MPa (250 bar).
The cylinder is painted subdued black.

Cylinder Ø A	Piston rod Ø B	AA	BB	Ø C	F	FF	G	H	I	K	L	N	R	V	X	Y	Push area cm ²	Pull area cm ²
25	12	52	65	35	-	25	12	44	18	14	112	G1/4	16	10	7	-	4,91	3,78
	16																4,91	2,90
32	16	57	70	42	-	28	12	46	19	14	120	G1/4	16	12	7	-	8,04	6,03
	20																8,04	4,90
40	20	70	85	50	-	36	20	55	24	18	144	G3/8	25	15	9	-	12,57	9,42
	25																12,57	7,66
50	25	80	95	60	-	43	25	55	22	25	140	G3/8	30	15	9	-	19,63	14,73
	32																19,63	11,59
63	32	110	130	75	91	50	30	51	23	30	180	G1/2	35	25	11	66	31,17	23,13
	40																31,17	18,61
80	40	138	159	95	114	59	40	59	23	32	188	G1/2	45	25	11	75	50,27	37,70
	50																50,27	30,63
100	50	168	195	115	136	78	50	66	28	40	206	G3/4	56	30	18	85	78,54	58,90
	63																78,54	47,37
125	63	212	249	145	174	90	60	76	30	50	232	G3/4	69	30	22	95	122,72	91,55
	80																122,72	72,45
140	70	227	264	160	189	116	70	76	36	58	258	G3/4	75	30	22	95	153,94	115,45
	90																153,94	90,32
160	80	252	298	185	208	137	80	92	45	65	310	G1	90	40	26	123	201,06	150,80
	100																201,06	122,52
180	90	284	330	205	238	152	90	99	45	70	320	G1	100	47	26	132	254,47	190,85
	125																254,47	131,75
200	100	320	380	230	260	175	100	112	48	80	355	G1 1/4	115	57	33	148	314,16	235,67
	140																314,16	160,27
250	125	390	450	298	330	225	120	125	48	100	400	G1 1/4	145	67	33	162	490,87	368,16
	160																490,87	289,81

Example of article number: DA05010700-0600
Front flange and spherical bearing at the piston rod,
cylinder Ø: 50 mm, piston rod Ø: 25 mm, and a
600 mm stroke.